

## OIF DDRP BASED ON OSPF / IETF PCE SOLUTIONS



A portable and conformant implementation of inter-domain protocols to speed up development of your optical control plane application.

### PRODUCT TARGET

The requirements for optical network management in the future include:

- Faster, interoperable, more dynamic provisioning of optical paths.
- Seamless integration with data networks
- More efficient use of network resources by providing protection through meshed topologies rather than rings.
- Improved support of transparent technologies and the ability to let service providers offer new services such as on-demand provisioning of optical paths.

The ITU-T has been working on a new architecture, called ASON - Automatically Switched Optical Network - for these networks. This architecture specifies how some administrative functions, in particular the provisioning of optical paths, should now be handled by a control plane that relies on dynamic routing and signaling protocols.

This architecture was formerly designed in the scope of a single carrier network (and even inside a single domain routing protocol area), while inter-domain consideration was postponed for future study.

Today the need for a means to support the ASON architecture within a multiple domain network is clearly identified.

Two solutions have been identified and can be used alternatively or simultaneously:

- OIF E-NNI OSPF based routing solution.
- IETF PCE solution.

#### OIF E-NNI based on OSPF

ITU-T proposes the G.7715 architecture and OIF extends the GMPLS architecture in conformance with ITU-T standards. This defines a domain-to-domain routing protocol (DDRP) solution based on OSPF. The aim is to allow the exchange of Traffic Engineering (TE) information between domains using an OSPF hierarchical architecture on top of the different domain (called Routing Control Domain or RCD).

With the solution, presented in ITU-T G7715 and OIF-ENNI-OSPF- 1.0, traffic engineering information (e.g. TE links and Transport Network Address) can be exchanged between different domains. With this solution an OSPF area is built on top of the multi domains network by the instantiation of one OSPF router per Routing Control Domain, the communications between OSPF routers is performed on top of tunnel such as GRE tunnel.

Regular Traffic engineering features (GMPLS-OSPF) can then be used to flood information inside that area.

To improve scalability, OIF and ITU-T solutions also support a multi level architecture:

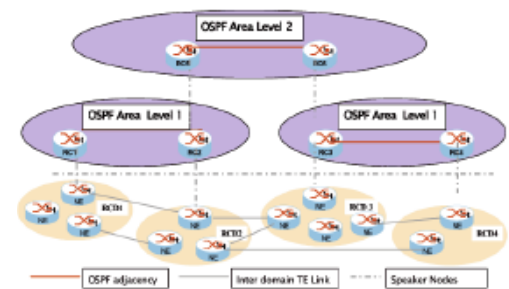

Hierarchical Multi level routing

Traffic Engineering information can be fed up and down between levels. When feeding up information, aggregation and summarization can be used to improve scalability. The downward feed of information is optional. When it is acceptable to share information between domain about internal topology, the feed down can be used to provide a complete view of the whole network (for instance in order to compute an end-to-end path). If the carriers want to keep information secret they can disable the feed down. End-to-end paths can then be computed using a path computation server.

The OIF solution reuses widely deployed protocols (OSPF-TE with GMPLS extensions).

### About Marben Products

Since the 1980's, Marben Products has been supplying portable software solutions that meet standards from the most established telecommunication standardization bodies. Marben Products is recognized as a leading provider of standards based protocol software for Service Providers, Equipment Manufacturers and Software Development Companies.

Marben Products delivers highly robust and efficient signalling, routing and AAA solutions for the network control plane of Next Generation Networks (NGN) and the service control plane of IP Multimedia Subsystem (IMS).

Telecom players such as: ADC, Adtran, Alcatel-Lucent, Amdocs, Ciena, Cisco, Ericsson, Fujitsu, HP, Motorola, Nortel, Oracle, Siemens Communications, Sprint Nextel, Tellabs, Telesciences have been trusting MARBEN™ Products for its high quality performance products, expertise and industry leading support.

Marben Products is an affiliate of NE Technologies, Inc.

## IETF PCE

As an alternative to OIF E-NNI routing solutions, especially when TE information confidentiality is required between domains (e.g. for inter carrier routing), or due to CPU resource limitation in the NEs, The IETF has developed the PCE solution.



PCE message protocol exchanges

The IETF PCE solution is focused on centralized Path Computation Elements. IETF PCE also relies on:

- A Communication Protocol (PCEP) to allow Path Computation Client (e.g. Ingress LSR) to request a Path Computation to a PCE.
- Discovery protocols that allow a PCC to discover PCE location and capability.

The key advantage of PCE is to allow PCEs (each one responsible for one domain) to collaborate and compute an end-to-end path without having to exchange any topology information across domains.

## KEY BENEFITS

- Fully portable C source code solution.
  - Reentrant and multi-thread safe.
  - Modular design compliant solution.
  - Open memory management.
  - Robust and scalable framework.
- All **MARBEN™** networking protocols solution can easily be ported in any environment thanks to its modularity on a wide range of systems supported (Linux RT, VxWorks, pSOS or Unix, Windows 2003...).

## TECHNICAL OVERVIEW

The Traffic Engineering development kit of the **MARBEN™** GMPLS suite includes the DDRP implementation. This TE Development kit offers capabilities:

- To query a database, fed with all received OSPF LSAs, and that contains both the control plane routing topology, and all the TE links advertised by the others control plane routing controllers.
- To ask for the advertisement of local TE links and Forwarding Adjacencies (FA), to stop the advertisement of local TE links or FAs, or to modify the attributes of an advertised TE link.

The **MARBEN™** DDRP solution enables speedy modification of an existing GMPLS application to support E-NNI routing.

The PCE implementation is an independent solution based on an entity and development kit with a two-level API.

In this architecture the **MARBEN™** OSPF module can emulate multiple OSPF routers (each one corresponding to a different DDRP level). The DDRP application just has to initialize one TE database per DDRP level supported on that box

The DDRP application can then easily feed up information by re-advertising TE information from one TE database to another. DDRP extension can request any information (TE link or TNA) to feed down.

The **MARBEN™** OIF E-NNI routing product supports multi level architecture.

The following diagram highlights the different modules (plain boxes) and the interfaces offered to an E-NNI application and a PCE application:

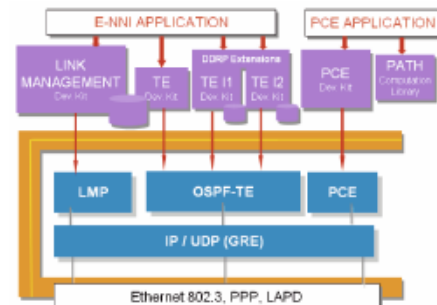

**MARBEN™** Inter domain routing offer.

The **MARBEN™** PCE is based on two separate components: the entity and the development kits.

- The **MARBEN™** PCE entity manages TCP connections and the keepAlive mechanism.
- The **MARBEN™** PCE Development kit provides a set of objects e.g. Constraints as bandwidth, metric, LSP Attributes, and load balancing (Allowing request of link/node/SRLG diverse path)..

The user-application can either act as a PCC, a PCE or both.

## CONFORMANCE

ITU-T G7715: Architecture and Requirements for Routing in the Automatically Switched Optical Network, ASON.

OIF2006.233.04: External Network-Network Interface (E-NNI) OSPF-based Routing -1.0.

RFC2328: OSPF intra-domain routing protocol

RFC4655: A Path Computation Element Based Architecture

draft-ietf-pce-pcep: PCE Communication. protocol v1.0

draft-ietf-pce-disco-protospf: PCE discovery based on OSPF. (available soon)

## CONTACTS

Marben Products  
176 rue Jean Jaures  
92800 Puteaux  
France  
Phone: +33 1 79 62 10 18  
Fax: +33 1 79 62 10 01

Sales information :  
sales@marben-products.com  
www.marben-products.com